

GLOCK INSTRUCTION FOR USE



for the Safe Action self-loading pistol

TAKE NOTE:

Always assume that the GLOCK pistol or any other firearm is loaded is capable of being discharged until you the user, have been personally convinced to the contrary. Until the magazine is removed and you have inspected the chamber and complete the unloading procedures as presented on page 21, the firearm must be considered to be loaded and capable of being fired. **Never** aim at persons when handling the weapon.

To reduce the possibility of an accidental discharge, do not place your finger on the trigger until the firearm is pointed at the target and you intend to fire. If you don't want the firearm to fire, keep your finger off the trigger

When firing with a two hand grip, the thumb of the weak hand should be on the weak hand side of the firearm, never behind the slide.

Before using the GLOCK pistols, the operating instructions and safety information in this manual must be read and understood.

Any firearm, including the GLOCK pistols, is a dangerous weapon, **it must not become accessible to unauthorised persons, especially children**

The manufacturer's warranty and liability is strictly limited to such as contained in the Terms of Delivery and Sale of GLOCK, Ges.m.b.h.

Place of Jurisdiction: Vienna/Austria

CONTENTS

- Take note
- General Description
- Main features
- Technical data
- Function of the weapon
- Components parts
- Exploded drawing
- Safety devices
- Sights
- Loading and Firing
- Unloading
- Dismantling
- Safety and guarantee instructions

GENERAL DESCRIPTION

The GLOCK Safe-Action self-loading pistol, with no-compromise design, combines virtually all the features demanded of the modern handgun of **today** - and **tomorrow** :

- Extreme low overall weight
- High Magazine capacity
- Maximum possible safety for the user
- Outstanding performance characteristics, combining advanced methods on manufacture with top-quality materials

The weapon is a mechanically-locked recoil-operated pistol with automatic firing pin and trigger safety as well as 'Safe-Action' trigger safety and 'Safe-Action' trigger system.

Each round is automatically loaded until the magazine is empty. The slide (1) will remain in the open position, held by the slide stop lever (27).

MAIN FEATURES

The new 'Safe-Action' trigger system offers the shooter the possibility getting off every shot quickly and without having to operate externally safety devices

The firing pin (5) is automatically put under partial tension after each round and is fully secured. There is no risk of an accidental discharge due to dropping the loaded weapon or due to shaking.

The pistol can only be fired by deliberately pressing the trigger (26). To do this the trigger finger must actuate the trigger safety. Discharge of a shot by off-centre, sideways pressure on the trigger is impossible.

The slide stop lever (27) and the **magazine catch (19)** are easily operated with shooting hand.

The receiver (17), made of plastic with hardened steel guides, has the outstanding features of **ideal dimensions, ideal receiver angle and low weight.**

The weapon has passed the most stringent military and/or industry tests and is regarded as an absolutely top-class product.

TECHNICAL DATA

Model	GLOCK 17	GLOCK 19	GLOCK 17L
-----	-----	-----	-----
Caliber	9x19mm	9x19mm	9x19mm
Length (slide)	186mm	174mm	225mm
Height inc. mag.	138mm	127mm	138mm
Width	30mm	30mm	30mm
Length between sights	165mm	152mm	205mm
Barrel length	114mm	102mm	153mm
Barrel profile - Hexagonal profile with right hand twist			
Magazine capacity std. (number of rounds opt.)	17 19	15 17	17 19
Mass weight			
- without magazine	625g	595g	670g
- empty mag. std.	78g	70g	78g
- optional	81g	73g	81g
- magazine full std.			
Muzzle velocity (Vo)	~360m/s	~350m/s	~385m/s
Muzzle energy (Eo) depending of ammunition used	~520 J	~490 J	~590 J
Trigger pull/trigger slack travel (taking up tension and releasing safety)	~10N/5mm	~10N/5mm	~10N/5mm
Trigger pull/trigger travel up to discharge	~2, 5kg/ 2, 5mm	~2, 5kg/ 2, 5mm	~2, 5kg/ 2, 5mm
-----	-----	-----	-----

Technical specs may be altered without notice!

STANDARD EQUIPMENT

- Pistol box (tight closing box for transport and safe helping, with locking facility)
- Spare magazine
- Cleaning rod with wad holder
- Cleaning brush
- Loading support

FUNCTION OF THE WAEPON

1) State of the weapon: **loaded**, i.e., a round in the barrel, firing pin (5) partially tensioned and secured, trigger (26), in the foremost position. the trigger safety integrated in the trigger is actuated with the trigger finger in order to pull the trigger all the way.

2) When the trigger slack is taken up to the first pressure point (travel 5mm) the weapon is released from safety, i.e. the trigger bar lies behind the safety ramp, the firing pin is under tension. As the trigger is pulled further back, the trigger bar releases the firing pin by means of the connector (24). The recoil impulse moves the slide (1) backwards. After about 3mm movement to the rear, the locking action between the barrel (2) and the slide (1) will be released, the barrel swings downwards over the locking block (22) and is retained in this position. The slide moves back into its final position on its own. During this return travel the cartridge is pulled out of the barrel by the extractor (11), and is then thrown out to the right via the ejector (23). The ramp in the slide rails actuates the connector and separates it from the trigger bar. This causes the trigger bar to be raised by the trigger spring (25) and to be brought back into the path of the firing pin nose.

3) The recoil spring now brings the slide forwards.

And this happens:

- The trigger bar is pushed onto the safety ramp by the firing pin,
- The firing pin safety is brought onto engagement
- The firing pin is put under partial tension
- A round is passed out of the magazine, and
- The barrel is locked with the slide

The weapon is again secured and ready to fire After the last round has been fired, the slide will be held in the open position by the slide stop lever (27).

COMPONENT PARTS OF GLOCK PISTOLS

1	Slide
2	Barrel
3	Recoil spring assembly
4	Inapplicable, incorporated in part 3
5	Firing pin
6	Spacer sleeve
7	Firing pin spring
8	Spring cups
9	Firing pin safety
10	Firing pin safety spring
11	Extractor
12	Extractor depressor plunger
13	Extractor depressor plunger spring
14	Spring-loaded bearing
15	Slide cover plate
16	Rear sight
16a	Front sight
17	Receiver
18	Magazine catch spring
19	Magazine catch

20	Slide lock spring
21	Slide lock
22	Locking block
23	Trigger mechanism housing with ejector
24	Connector
25	Trigger spring
25a	New York trigger spring
25b	New York trigger spring plus
26	Trigger with trigger bar
27	Slide stop lever
28	Trigger bar
29	Trigger housing pin
30	Follower
31	Magazine spring
32	Magazine floor plate
32a	Magazine insert
33	Magazine tube
34	Locking pin for non 9mm GLOCK pistols

(Table No. 1)

Above components part numbers are referring to the exploded drawing.

Note: A modified version of the Recoil spring/Recoil tube has been introduced in 1991 and is supplied then only as one complete **Recoil spring assembly** which **must** not be dismantled. Earlier supplied Recoil springs and tubes can certainly remain in use without problem.

Except for the following listed components, all other components are interchangeable with the GLOCK 17.

Parts not interchangeable with the GLOCK 17:

GLOCK 17L	GLOCK 19
No. 1, 2, 19, 24	1, 2, 3, 17, 20, 22, 26, 27, 31, 33

(Table No. 2)

For corresponding denomination of component parts please refer to table no.1

EXPLODED DRAWING
GLOCK 17

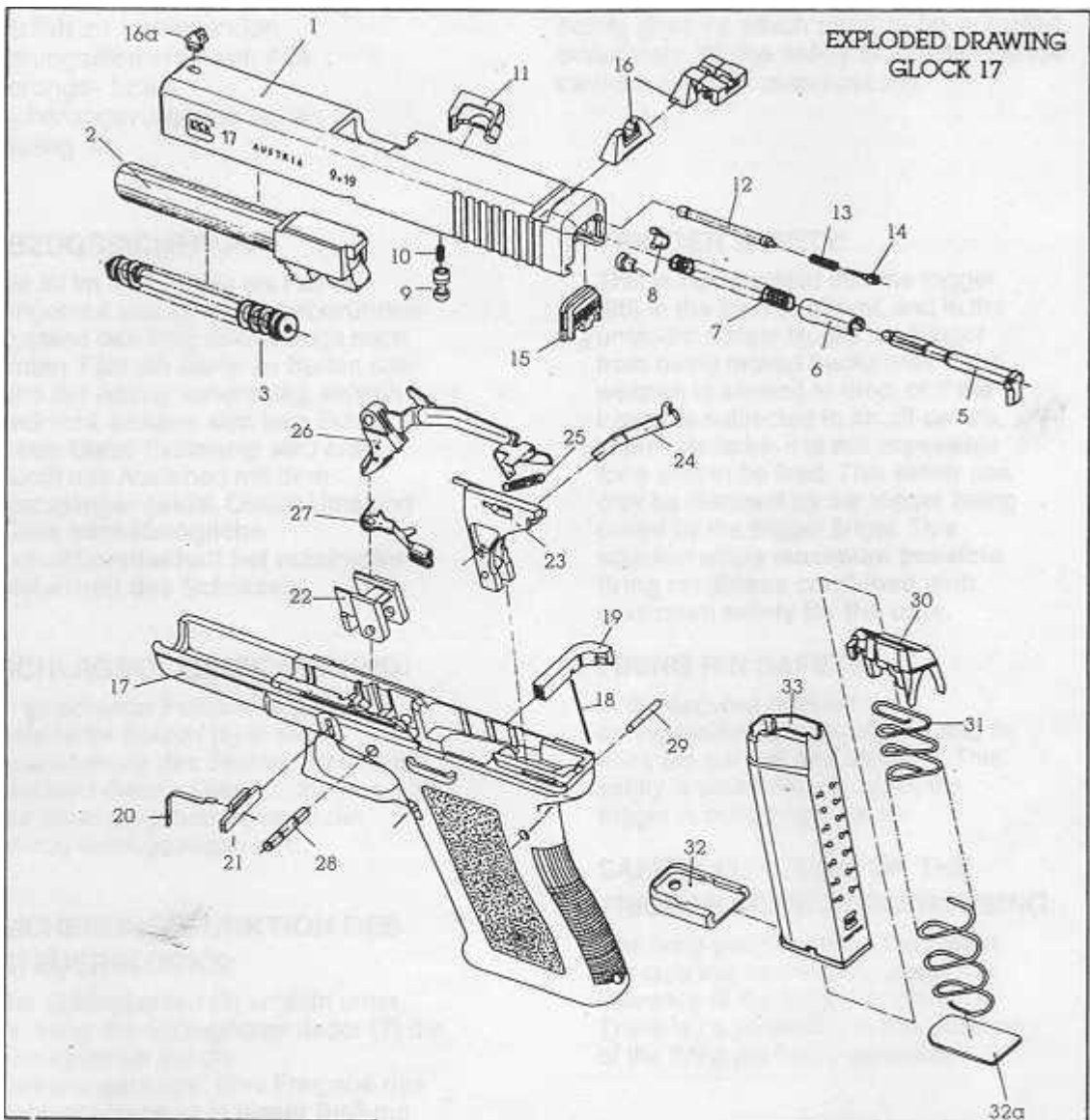

STANDARD (cal. 40, 10 mm, 45 ACP)
34 LOCKING BLOCK PIN

OPTIONAL (for part # 25):
25 a NEW YORK TRIGGER SPRING
25b NEW YORK TRIGGER SPRING PLUS

SAFETY DEVICES

The weapon has no externally located safety devices which need to be actuated separately. All the safety or safety release devices function automatically.

1. TRIGGER SAFETY

This is incorporated into the trigger (26) in the form of a lever, and in the untouched state blocks the trigger from being moved backwards. If the weapon is allowed to drop, or if the trigger is subject to an off centre, lateral pressure, it is still impossible for a shot to be fired. This safety can only be released by the trigger being pulled by the trigger finger. This situation offers **maximum possible firing readiness combined with maximum safety for the user.**

2. FIRING PIN SAFETY

In the secured position a spring-loaded pin (9) projects into the firing pin cut-out, and blocks it. This safety is only released when the trigger is pulled back.

3. SAFETY FUNCTION OF THE TRIGGER MECHANISM HOUSING

The firing pin (5) pushes the trigger bar onto the safety ramp under the influence of the firing pin spring (7). There is no possibility in this position of the firing pin being released.

SIGHTS

These consist of a rear sight (16) and a front sight (16a), in which white contrast elements are inserted. The rear sight is adjustable horizontally by displacement, while, for height adjustment. 3 different rear sight heights are available (0.4mm or 0.8mm above or 0.4mm below the normal height).

LOADING AND FIRING

1. The magazine is filled by each individual round being pushed into the magazine from the front, with the base of the round being pressed down first against the pressure of the magazine spring. If using the factory supplied loading support, slip support over the magazine and place magazine on a solid surface. Hold loading support firmly and place thumb on top of loading device: Press down loading device against tension of magazine spring and, while keeping support down, insert a round as far as possible. While pressing round downwards, slide support upwards (release magazine spring) and the round will slide into its rest. Repeat operation for subsequent rounds.
2. Introduce or insert the magazine into the magazine shaft until the magazine catch engages fully

3. Pull back the slide with free hand, and allow it to spring forwards into the final position. **The trigger finger of the shooting hand remains outside the trigger guard.** The weapon is now secured and ready to fire.
4. After the last round has been fired, the slide remains open. Remove the empty magazine from the weapon by pushing the magazine catch (19). Insert a new magazine and then either push the slide stop lever (27) downwards (see photo), or pull the slide slightly backwards and allow it to spring forwards. The weapon is now again secured and ready to fire.



UNLOADING

1. Remove the magazine (see photo).



2. Pull slide (1) back to eject the round which is in the barrel (2).
3. Check to ensure that there is no round in the barrel
4. Allow the slide to spring forwards and pull the trigger into the full pulled position.

DISMANTLING AND REASSEMBLING

1. For normal cleaning, it is sufficient to dismantle the weapon into its **MAIN COMPONENT PARTS**
 - slide (1)
 - barrel (2)
 - recoil spring assembly (3)
 - receiver (17)
 - magazine
2. For maintaining and cleaning the weapon, it is recommended that the cleaning equipment provided as part of the accessories be used, together with the cleaning wadding and special gun greases and oils available from specialist dealers.
3. **The GLOCK pistols are stripped into the main component parts** in the following order:
 - removing the magazine
 - checking safety (ensuring there is no round in the barrel)
 - pulling trigger right back
 - removing barrel from slide. Before the slide and the receiver are dismantled any further, attention is drawn to the safety and guarantee conditions.

4. **Removal of the slide (see photo)** is carried out as follows:
 - Grasp the pistol in the right or left hand in such a way that four fingers rest over the slide and the thumb rests on the rear side of the receiver.
 - Using the fingers draw back the slide (1) about 3mm
 - Pull the slide lock (21)
 - Push the slide forwards and separate it from the receiver.



If the slide is drawn back too far (more than 3mm), the trigger will move to the foremost forward position. The slide will then **not** separate from the receiver (17). **Do not use force**. The trigger must first be pulled all the way back.

5. Removal of the barrel (see photo) is carried out as follows:
 - Push the recoil spring assembly (3) somewhat forwards with the thumb and raise it
 - Take the recoil spring assembly out of the slide (see photo 4).
 - Grasp the barrel on the barrel locking piece, push it slightly forwards, raise it and pull it backwards out of the slide. **Reassembling the GLOCK pistols** is carried out in the reverse order to the above.



SAFETY AND GUARANTEE INSTRUCTIONS

1. If the weapon is dismantled by the purchaser or by any third parties further than described in this user's instruction, and if, as a result of inappropriate handling or incomplete reassembly, damage or malfunctions are caused, as a result of which the safety devices are rendered ineffective, then the purchaser shall forfeit any claim to guarantee against damages thereby incurred to persons or property.
2. Any change to the basic construction of the weapon, in particular by the circumvention of the safety devices, is strictly prohibited for safety reasons, and precludes the use of the weapon.
3. The following actions are **not** permitted on the weapon since they could lead to damage:
 - With the weapon unloaded the trigger (26) shall not be manually brought into the foremost position and actuated. The trigger shall only be brought into its foremost position by pushing back the slide (approx. 15mm or more)
 - Should, with the slide disassembled, the trigger (26) be inadvertently brought into its foremost position, then the trigger shall be only actuated when, at the same time, the triggerbar is pushed forward (in muzzle direction).

- With the slide removed, it is not permitted to tension and spring the firing pin (5) forward, since this could damage the firing pin safety.
 - The steel insert located in the cover plate (15) to the slide must not be removed.
4. No liability whatever can be accepted if inexpertly manufactured or inexpertly filled ammunition is used.
All liability whatever is excluded in the event of these instructions not being observed.

CHECK OF SAFETY DEVICES

The following safety checks are to be carried out at regular intervals, e.g. before each use or when cleaning the weapon after use:

a) Function testing the trigger safety:

- Remove the magazine from your pistol and reassure that there is no cartridge in the barrel. Then the trigger may be pulled back.
- Bring back the trigger in its most forward position by cycling the slide. The trigger safety (lever integrated in trigger) should then be properly engaged.
- When lateral pressure is applied on the trigger the safety should keep engaged, blocking the trigger movement.
- **Failure of the trigger safety to properly engage or block indicates that it is defective. Do not reload or use your weapon again and contact GLOCK Ges.m.b.H. or an authorised GLOCK armorer immediately.**

b) Function testing the firing pin safety:

- Dismantle the weapon into its main components as described previously and remove the recoil spring/recoil spring tube and barrel from the slide.
- Hold the slide in a muzzle down position and depress the firing pin safety. The tip of the firing pin should move forward and be visible protruding from the firing pin hole.
- Keep the firing pin safety depressed and shake the slide. The firing pin should be distinctly heard moving freely.
- Draw back manually the firing pin about 0.2 in.
- Hold the slide in a horizontal position and push forward the firing pin toward the muzzle, firing pin safety being engaged. **The firing pin should not protrude from the firing pin hole. If it does, the firing pin and the firing pin safety should be replaced.**